

TECHN. DATEN (TECHNICAL DATA):

NENNDRUCK (NOMINAL PRESSURE) P_N 70 MPa (700bar)
 PRÜFDRUCK (TEST PRESSURE) P_p 84 MPa (840bar)
 GEWICHT (WEIGHT) 19,9 kg
 (INKL. 0,3m SCHLÄUCHE U. KUPPLUNGEN; INCL. 0,3m HOSES AND COUPLINGS)
 ÖLBEDARF (REQUIRED OIL VOLUME) 0,17 l

STEUERUNG (SAFETY FEATURES)

SICHERHEITSSCHALTUNG ENTSPRECHEND EN 13204
 (WHEN CONTROL KNOBS IN NEUTRAL POSITION,
 OIL CIRCULATES WITHOUT EXERTING PRESSURE)

Klasse (CLASS):

EN 13204 AS 49/710-20

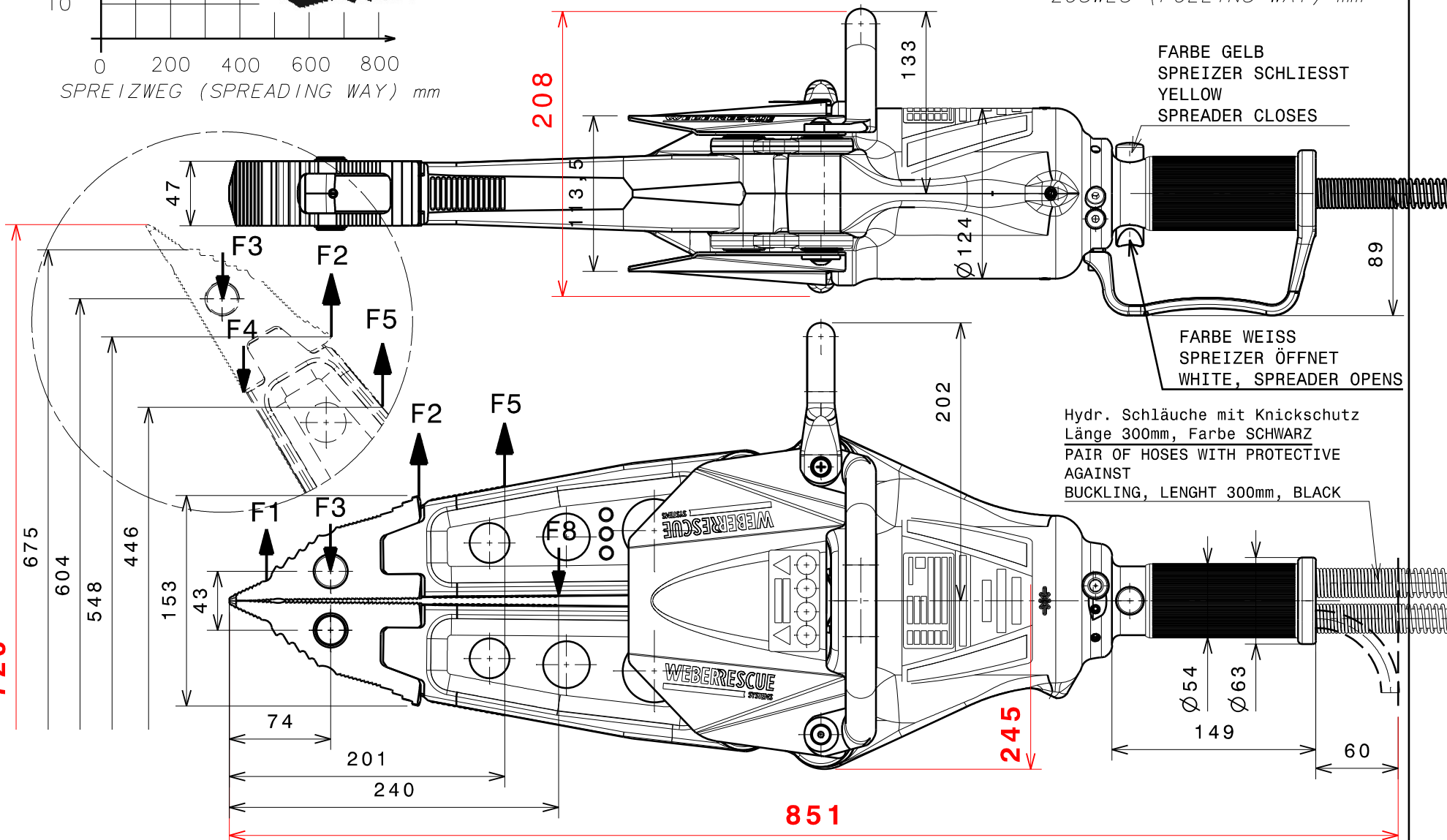
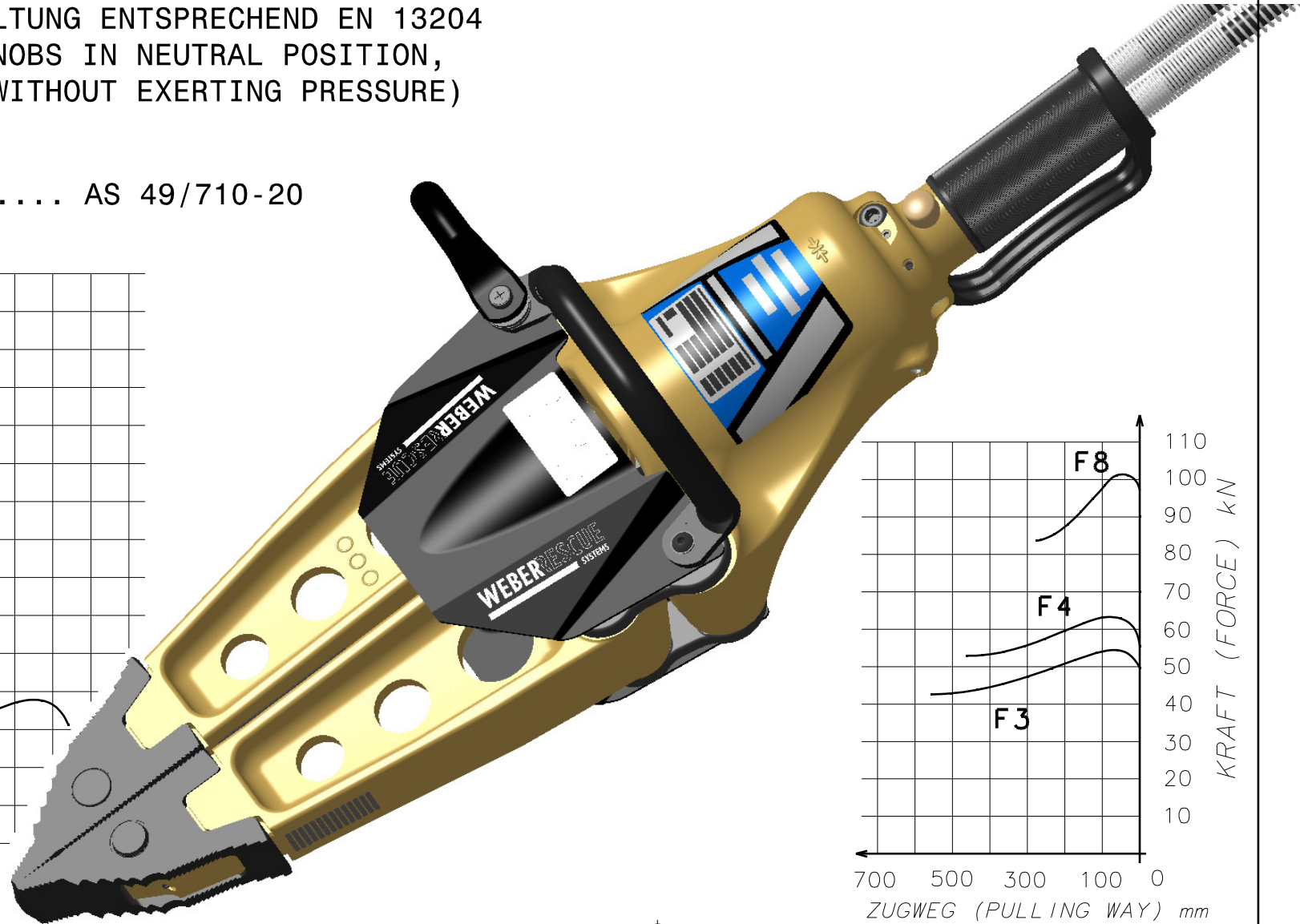
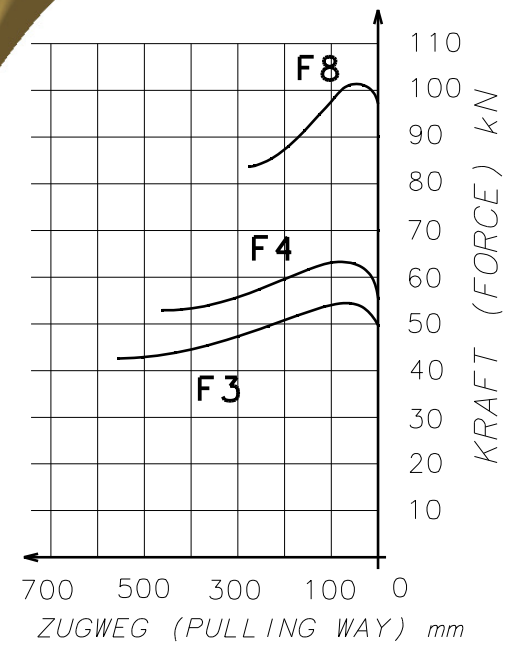
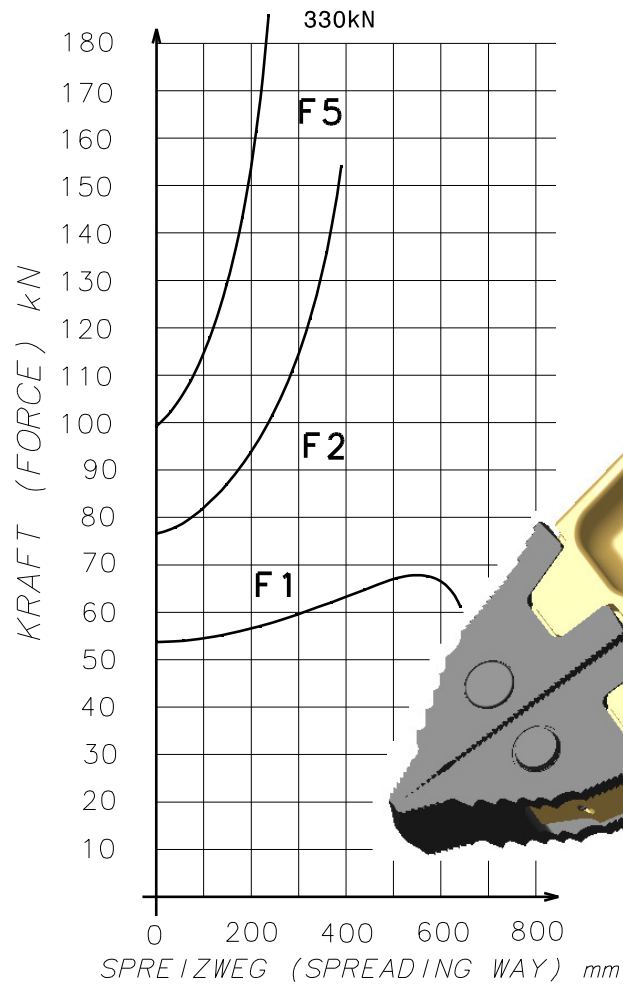

GEPR. JSC CHECK.

GEZ. KST DRAW. DAT. 21.02.06

KST 24.09.13
 GEÄND. MODIF. AEND.-DATUM MOD.-DATE

130666 D

AEND.-NR. MOD.-NO. REVISION REVISION

FREIMASSTOLERANZEN (GENERAL TOLERANCES)	LAENGENMASS (LENGTH)mm	...50	50...250	250...1000	1000...	WINKELMASS (ANGLE)	...180°
	TOLERANZ (TOLERANCE)mm	±1,5	±2,0	±3,0	±5,0	TOLERANZ (TOLERANCE)	±10°