

TECHN. DATEN (TECHNICAL DATA):

NENNDRUCK (NOMINAL PRESSURE) PN 70 MPa (700bar)
 GEWICHT (WEIGHT) 18,2 kg (INCL. AKKU)
 MAX. SCHNEIDKRAFT (CUTTING FORCE) ... 493 kN (50t)
 BETRIEBSSPANNUNG (OPERATING VOLTAGE) . 28 V DC

Klasse (CLASS):

DIN 14751/4 C150-H-E-I
 EN 13204 (IN ANLEHNUNG/ ACCORDING TO) BC160-H-18
 NFPA 1936 A6/B7/C6/D7/E8

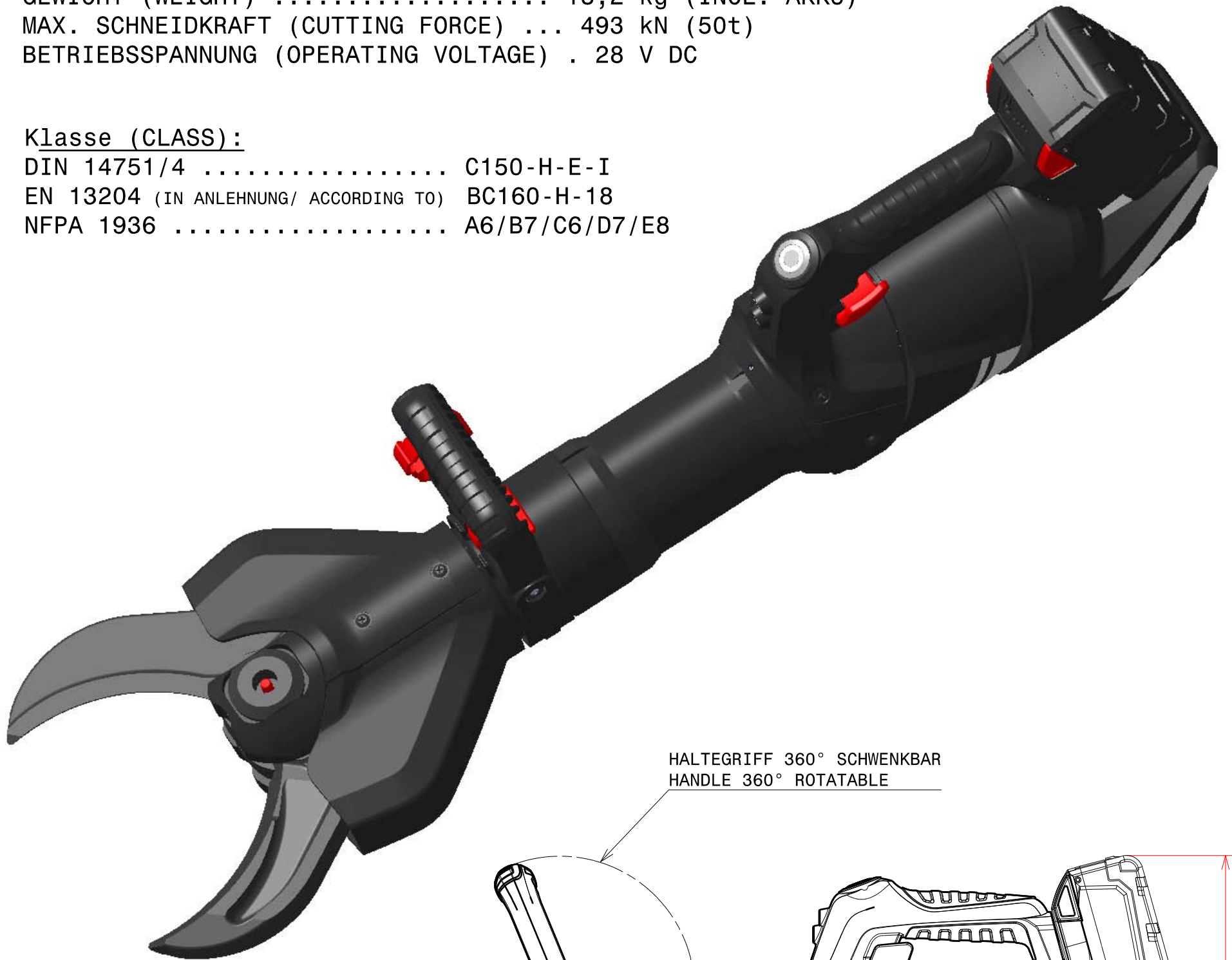

HALTEGRIFF 360° SCHWENKBAR
HANDLE 360° ROTATABLE

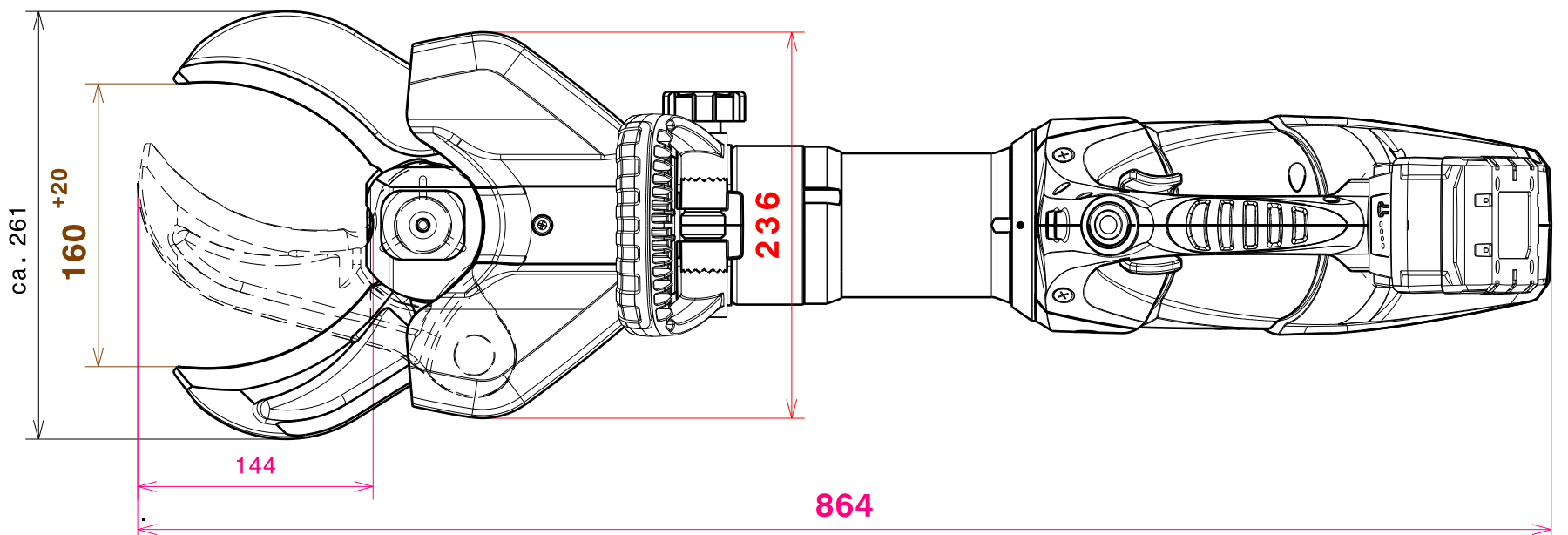
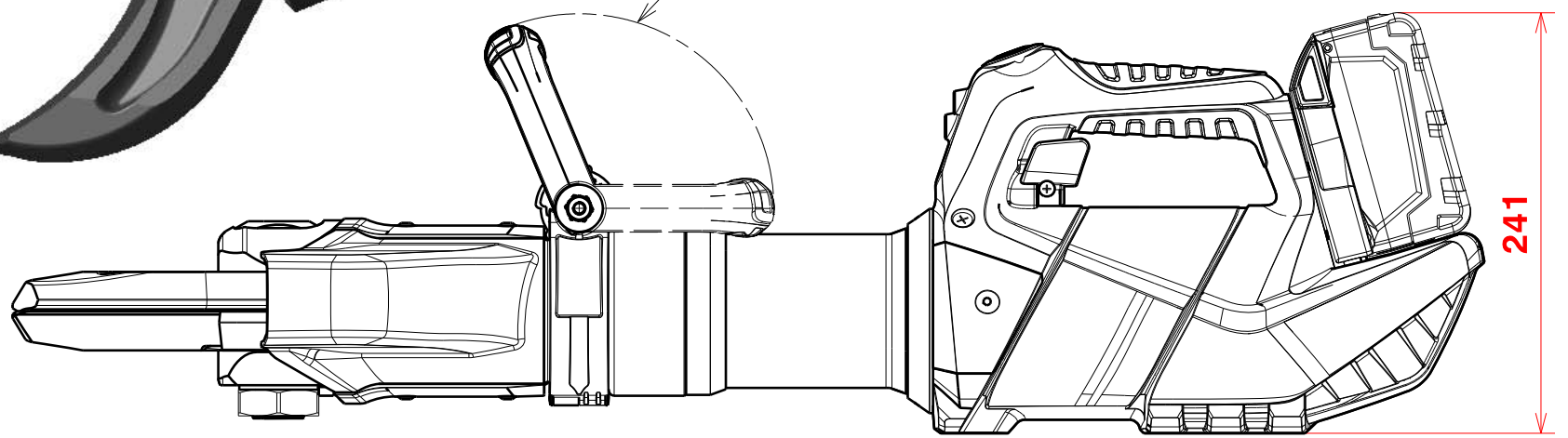

GEPR. JSC
CHECK.

GEZ. KST
DRAW. DAT. 26.05.15

GEAEND. Dst
MODIF. 20.06.16

AEND.-NR. 160432
MOD.-NO. B
REVISION DATUM
REVISION 20.06.16

FREIMASSTOLERANZEN (GENERAL TOLERANCES)	LAENGMASS (LENGHT)mm	... 50	50...250	250...1000	1000...	WINKELMASS (ANGLE)	...180°
	TOLERANZ (TOLERANCE)mm	±1,5	± 2,0	± 3,0	± 5,0	TOLERANZ (TOLERANCE)	±10°