

TECHN. DATEN (TECHNICAL DATA):

NENNDRUCK (NOMINAL PRESSURE) P_N 70 MPa (700bar)
 GEWICHT (WEIGHT) 24 kg (INCL. AKKU)
 BETRIEBSSPANNUNG
 (OPERATING VOLTAGE) 28 V DC

Klasse (CLASS):

DIN 14751/4 S40-E-I
 EN13204 (IN ANLEHNUNG/ ACCORDING TO) BS53/800-24

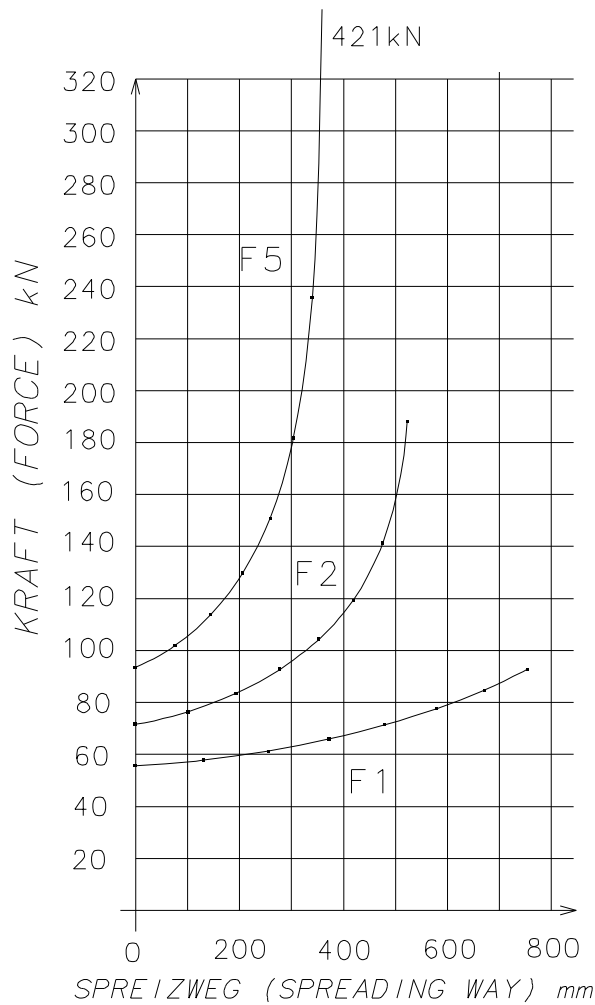

ALLE KRÄFTE BEI 70 MPa U.
OHNE WIRKUNGSGRAD
DIAGRAMM AT 70 MPa
AND WITHOUT EFFICIENCY

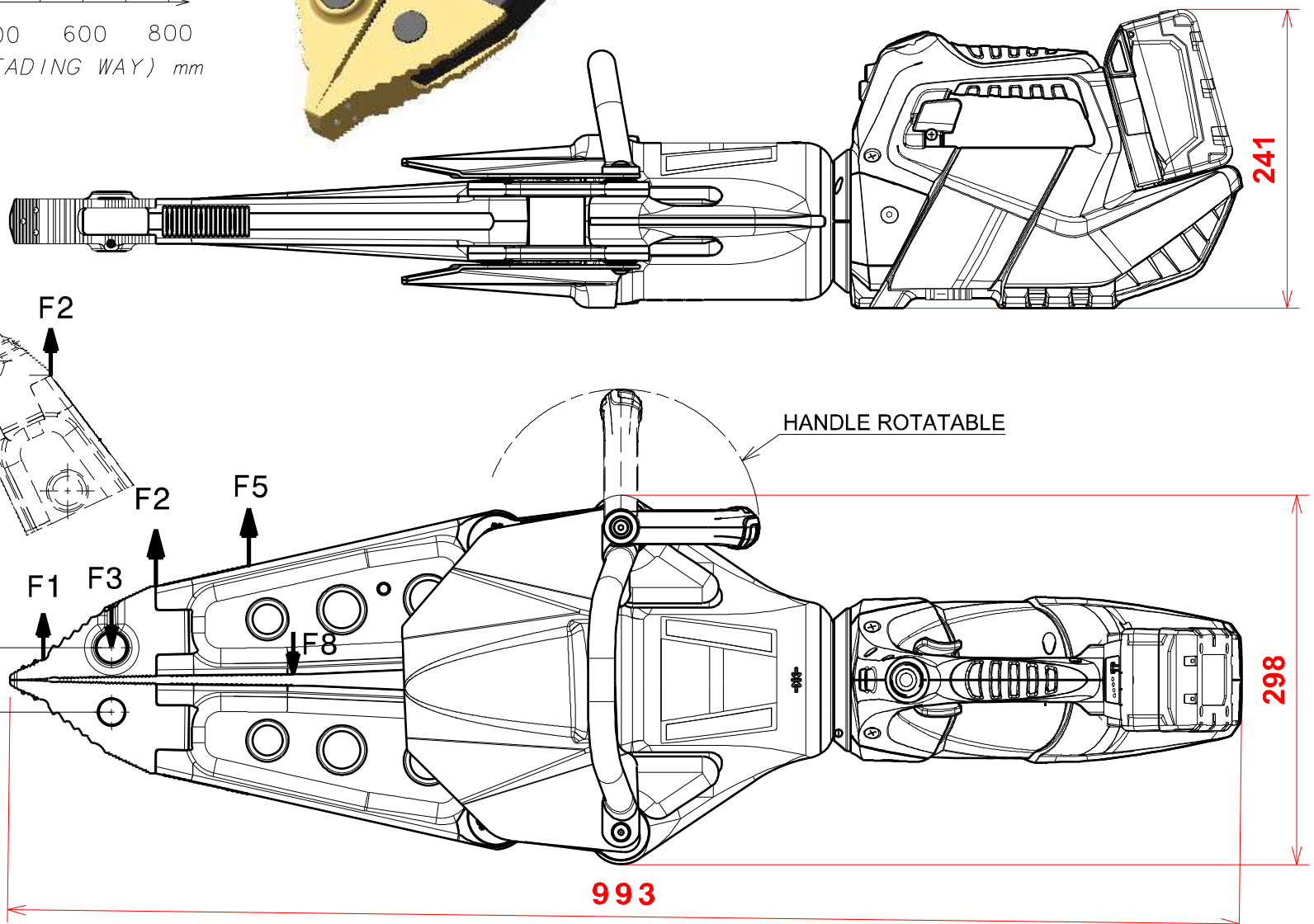
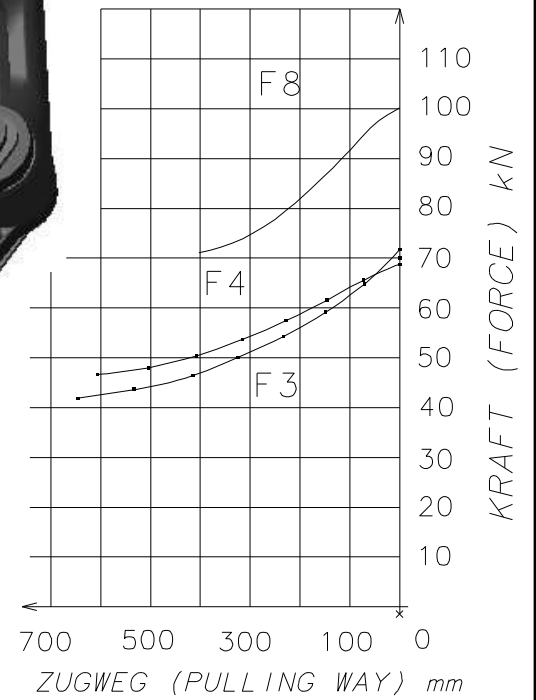

GEPR. JSC
CHECK.

GEZ. KST
DRAW. DAT. 22.05.15

KST
AEND.-DATUM 22.02.16
MOD.-DATE

160118
B

AEND.-NR.
MOD.-NO.
REVISION
REVISION

FREIMASSTOLERANZEN (GENERAL TOLERANCES)	LAENGENMASS (LENGHT)mm	...50	50...250	250...1000	1000...	WINKELMASS (ANGLE)	...180°
	TOLERANZ (TOLERANCE)mm	±1,5	±2,0	±3,0	±5,0	TOLERANZ (TOLERANCE)	±10°